

MN-NIO Network IO Monitor Manual

Table of Contents

CHAPTER1 PRODUCT OVERVIEW	2
1.1 FUNCTIONAL FEATURES:	2
1.2 TECHNICAL PARAMETERS	2
CHAPTER2 INSTALLATION INSTRUCTIONS	3
2.1 PRODUCT SIZE	3
2.2 INSTALLATION INSTRUCTIONS	3
CHAPTER3 EQUIPMENT INTERFACE DESCRIPTION	5
3.1 EQUIPMENT INTERFACE	5
CHAPTER4 CONFIGURE	12
4.1 GENERAL STEPS	12
4.2 CONFIGURATION METHOD	12
CHAPTER5 TYPICAL USAGE	17
5.1 DEVICE CONFIGURATION	17
5.2 ACQUIRE HARDWARE ACQUISITION DATA	23
5.3 LUA SCRIPTS	29
APPENDIX	31

Chapter1 Product Overview

MN-NIO is a programmable field control intelligent device that supports the Internet of Things launched by Guangzhou Wangkong Ltd. It supports multiple I/O interface types, collects data from front-end sensors in real time, and establishes a secure two-way connection between the device and the cloud through the mainstream Internet of Things protocol MQTT communication, helping to quickly implement Internet of Things projects. NIO also supports traditional networking methods, connecting the collected data to various industrial data platforms through Modbus TCP, SNMP or BACNet.

As a standard IoT device, MN-NIO can be directly connected to major mainstream IoT public cloud platforms. The device uses the standard IoT MQTT protocol to report the collected data to the IoT platform in accordance with the standard data format defined by each IoT platform, helping software developers focus on their business and quickly build IoT applications. The device supports Lua scripts, which is convenient for user-customisable logic programming for various application scenarios, and has the ability to independently and intelligently control after being off-line.

1.1 Functional Features:

- High performance industrial grade RISC-V-64 processor.
- Stable and reliable, industrial-grade application design, each interface circuit has industrial-grade electromagnetic immunity.
- Easy to use, with GUI configuration tools, it's convenient for batch installation and quick configuration of products. Support online remote upgrade of devices. Facilitating product deployment and maintenance, effectively reducing labor costs.
- PoE power supply: Compliant with IEEE 802.3af standard PoE electrical devices (PD devices), Type 1 devices, supporting both Mid Span and End Span power supply modes. Simplified installation, convenient deployment of UPS centralized power supply guarantee.
- The device supports Lua scripts, which facilitates user-customizable logic programming.
- The device supports multiple standard communication protocols, MQTT/Modbus TCP/SNMP/BACnet. Select the appropriate communication protocol according to the characteristics of the application scenario.
- The device supports the standard MQTT communication protocol and has secure, stable, and efficient IoT communication connection capabilities, helping to quickly achieve data communication between devices, applications, and cloud services.
- Data transmission adopts secure encryption method. Provide TLS standard data transmission channels to ensure data confidentiality and integrity.
- Provide a one machine one password device authentication mechanism to reduce the security risk of device breaches.
- Provide a device permission management mechanism to ensure secure communication between devices and the cloud.
- Seamless integration of various products and services from major cloud platforms in the market, AWS/Azure/Tuya, allowing for flexible construction of complete solutions from smart device terminals to business service platforms for different application scenarios.
- Supports simultaneous access to two cloud platforms and can send data to two centers simultaneously, achieving redundant backup systems.
- Flexible expansion to meet diverse needs. Expandable modular I/O, providing users with a variety of I/O and communication modules for data acquisition, control, and transmission.

1.2 Technical Parameters

Digital Input	8-channel DI digital input interface, Input signal type 1 (IEC61131) . DI1-DI4 are sink (IEC positive) type. DI5 and DI8 can be configured with the sink/source (IEC positive/negative) type.
Digital Output	4-channel DO mechanical relay output interface. Switch capacity: 5A, 240V AC/30V DC .
Analogue input	8-channel Analogue 4-20mA current input interface. The input resistance is 100 ohms.
Network communication interface	10/100M Base Tx Ethernet port (supports PoE power supply).
Communication Protocol	Support multiple TCP/IP based application layer protocols: MQTT/MQTTS, SNMP, Modbus TCP, BACNet
Console interface	1 RS232 configuration port, baud rate 115200bps, 8N1, no flow control.
Serial communication interface	1 RS485 ports, maximum baud rate of 200Kbps, isolation voltage of 3000VDC.

Power supply	You can choose PoE power supply or auxiliary power supply. PoE power supply: Compatible with the IEEE 802.3af standard. Type 1 device, Class 3. Auxiliary power supply: DC12V. Use a power supply that meets the SELV (Safety Ultra Low Voltage) requirements and supply DC12V according to the LPS (Restricted Power Supply) rated voltage of IEC60950-1.
Rated power	< 2W, when there is no external power supply.
Working temperature	-25~+70°C
Storage temperature	-30~+85°C
Work storage humidity	5~95% RH, No condensation
Appearance size	Length*width*height(mm) = 166*88*61
weight	About 600g

Chapter2 Installation Instructions

2.1 Product size

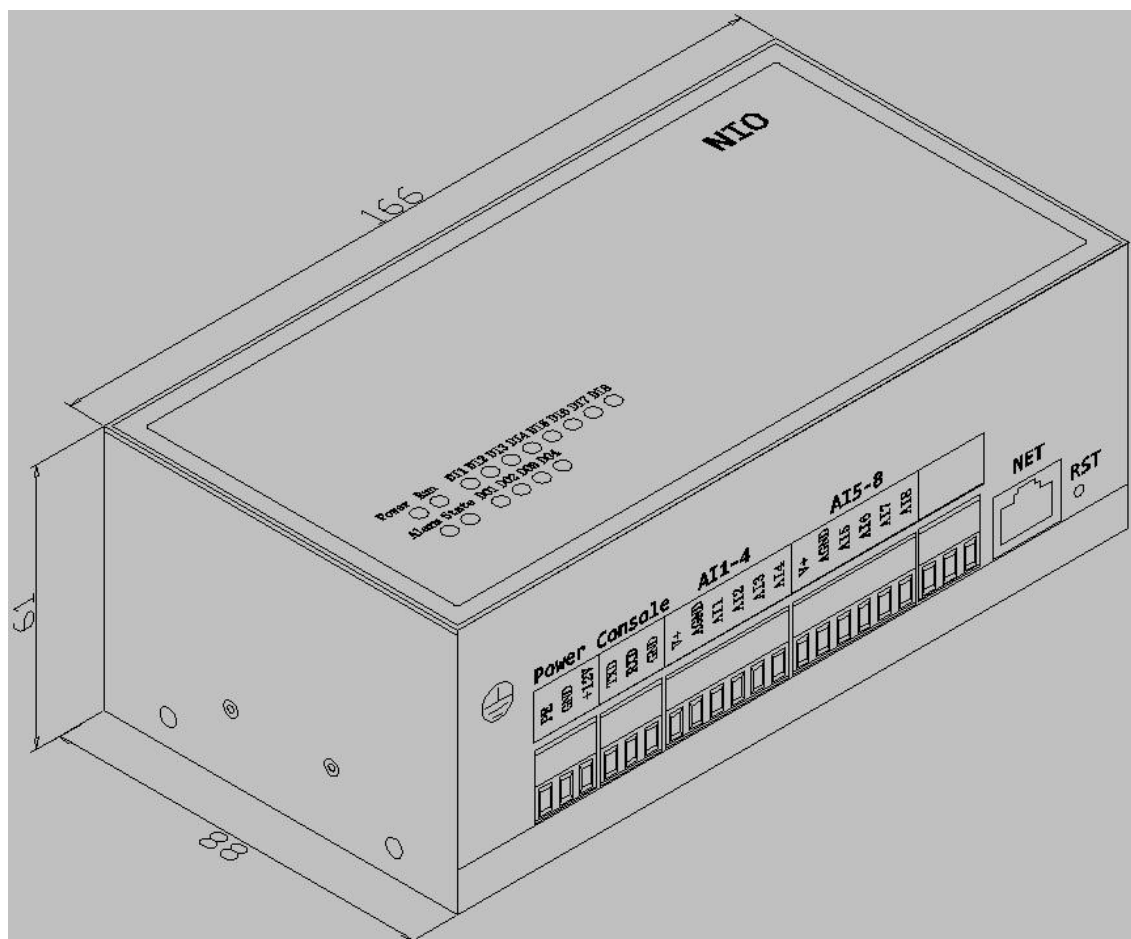

2.2 Installation Instructions

MN-NIO supports DIN rail installation and wall installation, and the installation location and method should be selected reasonably according to the on-site environment.

When selecting DIN rail installation, first connect the product body to the rail specific plastic socket through the accessory ears, and then install it as a whole onto the DIN rail.



Special plastic card holder for guide rail: 

Chapter3 Equipment Interface Description

3.1 Equipment interface

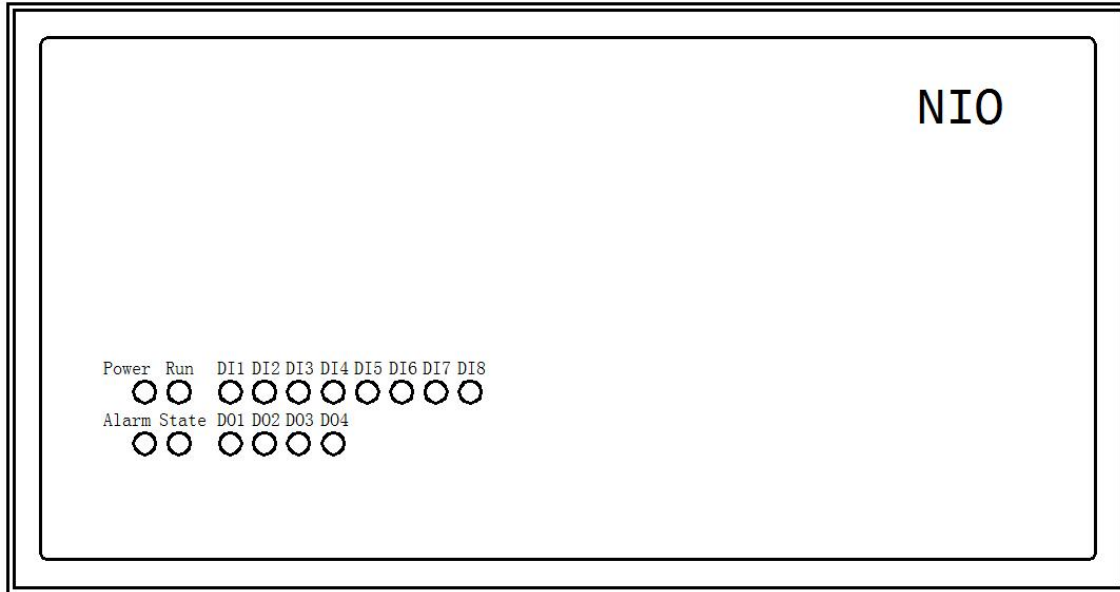

NIO panel LED light layout

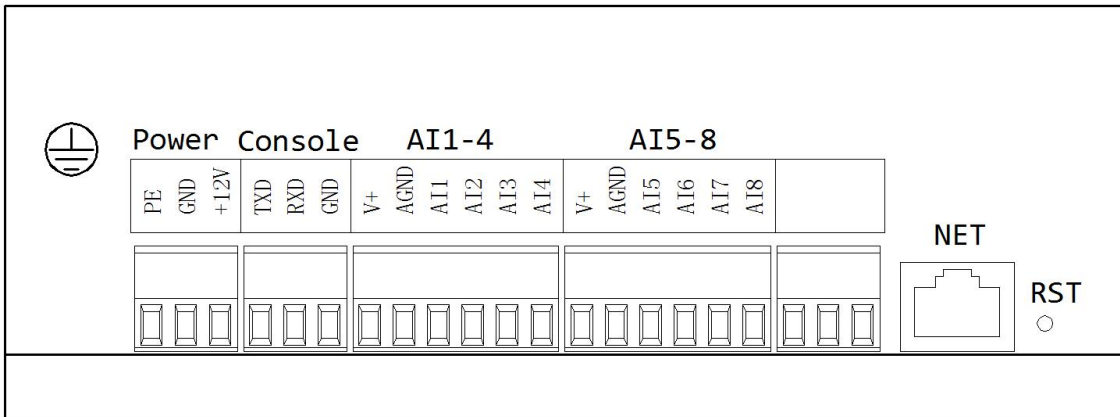

NIO terminal block 1 interface layout

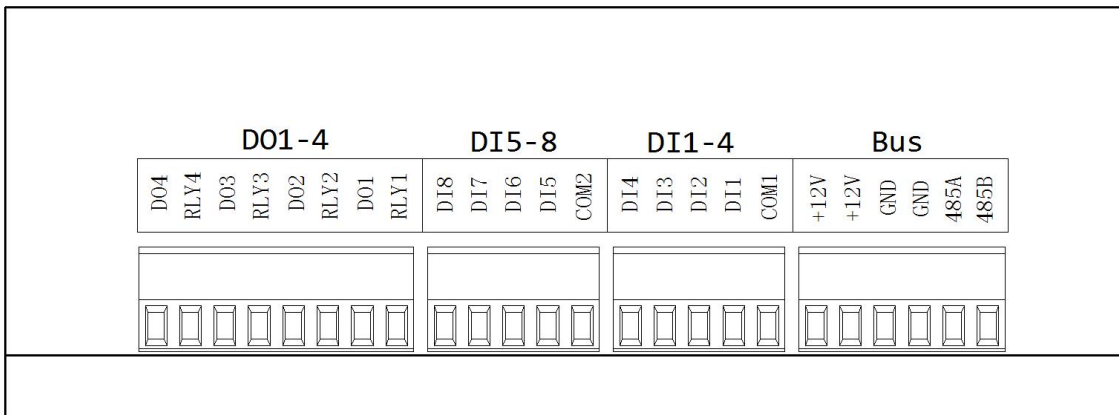

NIO terminal block 2 interface layout

Protective Earthing:

⊕: All equipment with safety level class I and all large metal components must be connected to a protective grounding. This is a basic requirement to ensure that users are not electrocuted by the device. This can also be used to release interference transmitted through external power cables, signal cables, or cables connecting IO devices.

Power : Auxiliary power interface:

PE	Protective Earthing. The device is connected internally to the casing.◦
GND	Auxiliary power supply negative pole. It also serves as a reference ground for the working circuit of the equipment.
+12V	Auxiliary power supply supplies positive pole.

Console: Configure serial port:

TXD	Signal transmitter, connected to the RXD of the upper computer.
RXD	Signal receiver, connected to the TXD of the upper computer.
GND	Signal ground.

NET: Ethernet interface:

Standard 10/100Base Tx Ethernet communication interface, supporting IEEE 802.3af standard PoE power supply.

RST: reset button:

When the device is running, press and hold the Reset button for more than 1 second but less than 5 seconds to restart the device. Press and hold for more than 5 seconds and then release it to restore the factory default settings and restart.

AI: Analogue input interface:

Input Type: 4-20mA current signal.

Isolation: Non-galvanic isolation between the controller and the Analogue inputs, as well as between the Analogue input channels.

Accuracy: $\pm 0.5\%$ of Full Scale (FSR)

V+	The maximum output power is 8W, and the rated voltage is 12V.
AGND	Analogue signal input common ground.
AI1-AI8	Postive pole of analogue signal input.

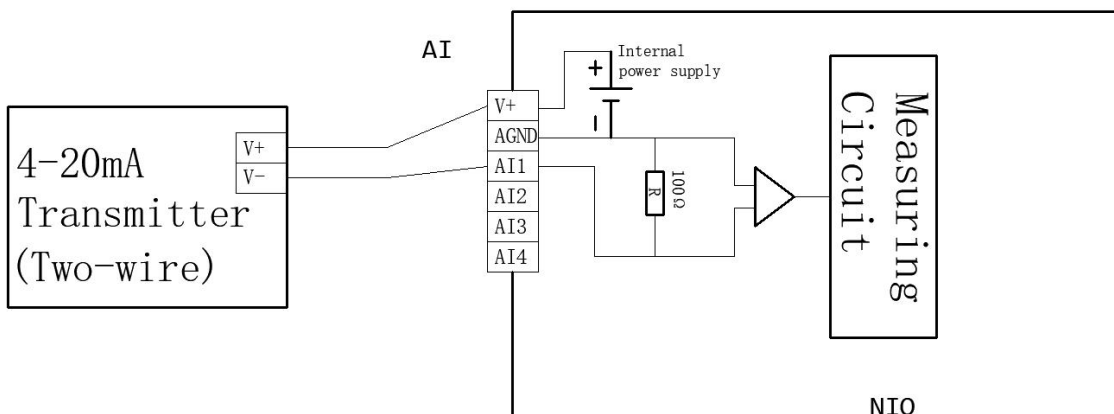

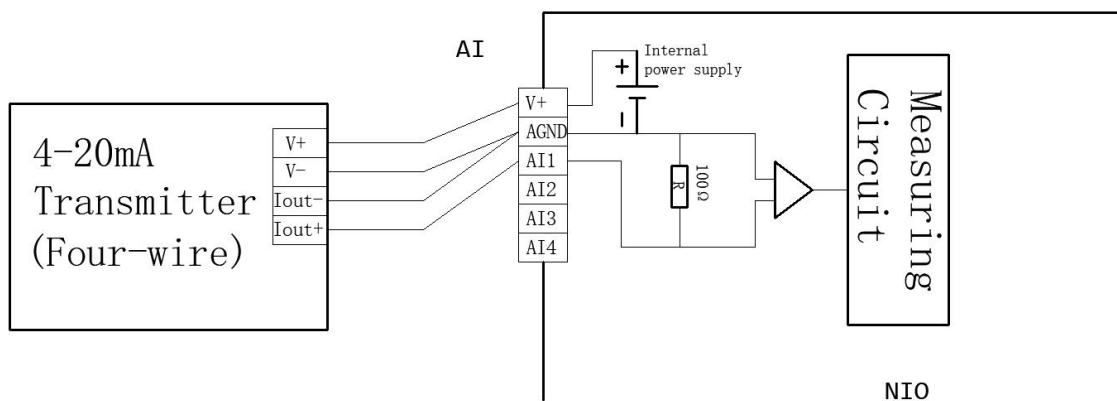
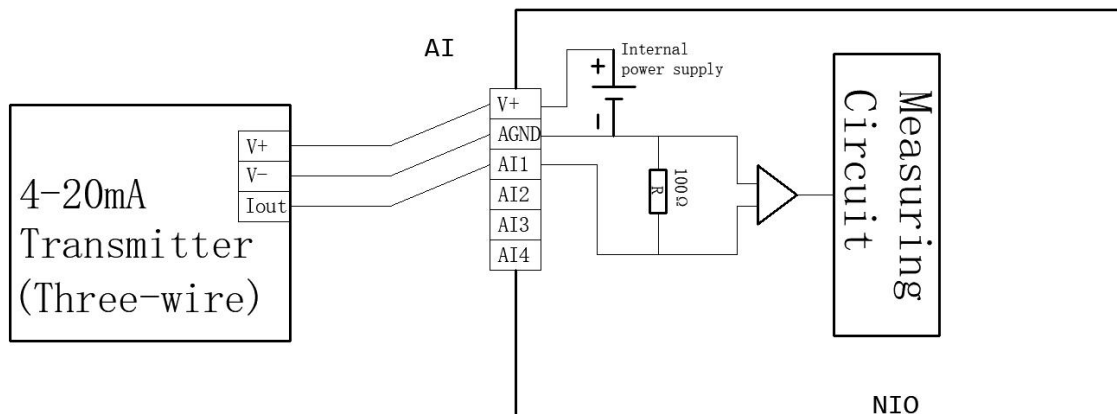

Note: The rated voltage of the built-in power supply is DC12V, and the maximum output power is 8W.

The transmitter can also be powered by an external power supply, with other voltage values such as DC24V.

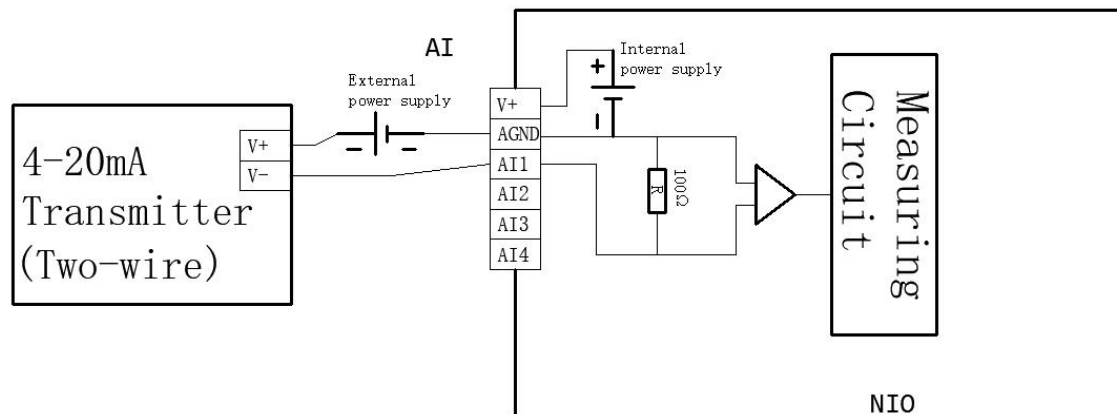

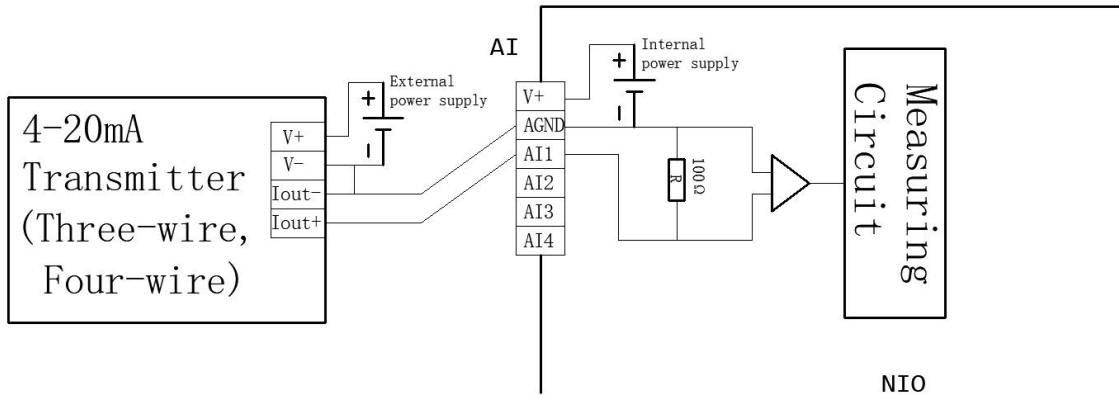

The graph of the input current value as a function of the output measured value is shown in the figure below:

Output: Measurement

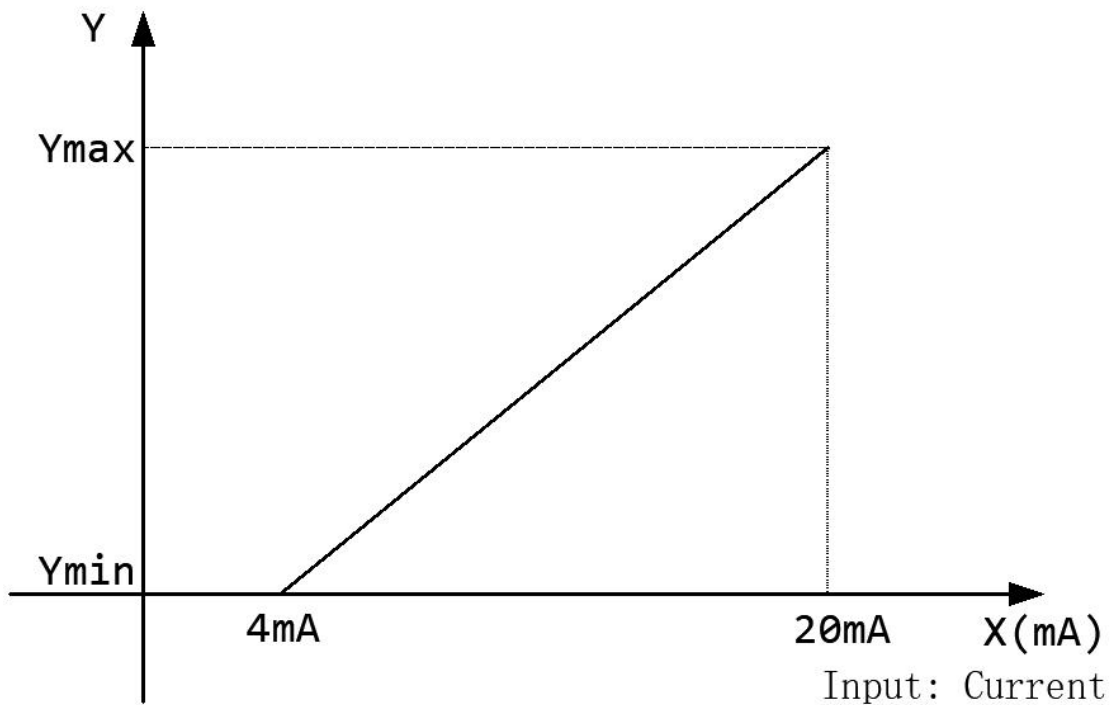

The AIO input X (current value) and output Y (measured value) are calculated as follows:

$$Y(x) = \begin{cases} Y \text{ min,} & X < 4mA \\ (X - 4mA) * \frac{Y \text{ max} - Y \text{ min}}{20mA - 4mA} + Y \text{ min,} & X \geq 4mA \end{cases}$$

Ymin corresponds to the **Minimum value(lower limit of the effective value)** in the AIO supervisor point configuration.
 Ymax corresponds to the **Maximum value(upper limit of the effective value)** in the AIO supervisor point configuration.

DI: Digital signal input interface

Input Type: Type 1 (IEC61131), Dry contact

Isolation: The input terminal is photocoupled and isolated from the inside, and the input terminal is not isolated.

DI1-4 Digital signal input interface:

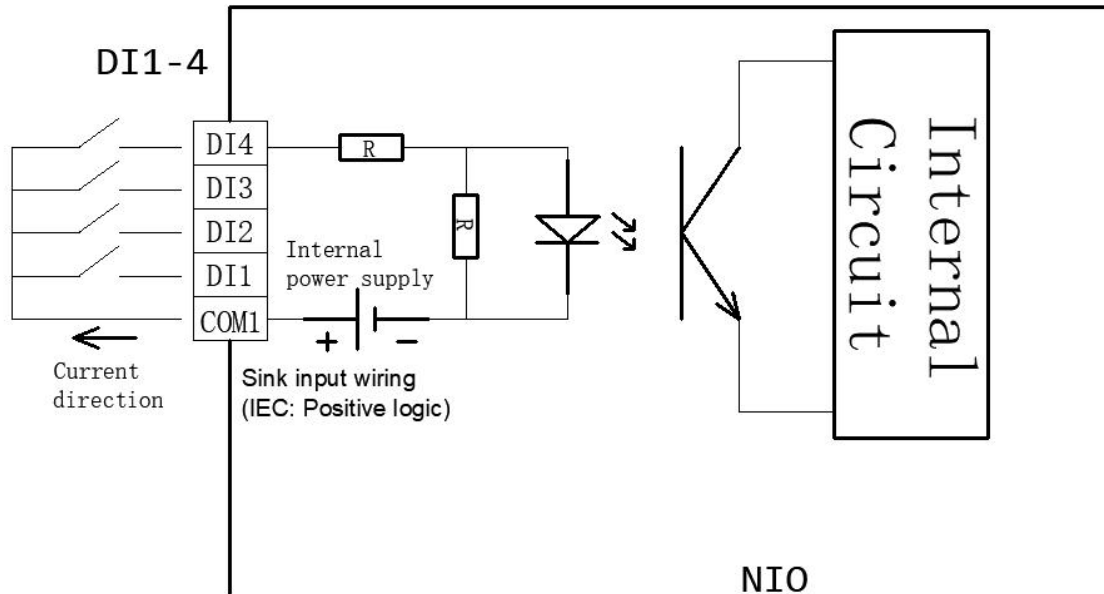

COM1	DI1-4 digital signal input common terminal.
DI1-4	DI1-4 digital signal input.

Note: DI1-4 is fixed to sink type. The device already has a built-in power supply for the detection loop.

DI1-4 Digital signal input interface:

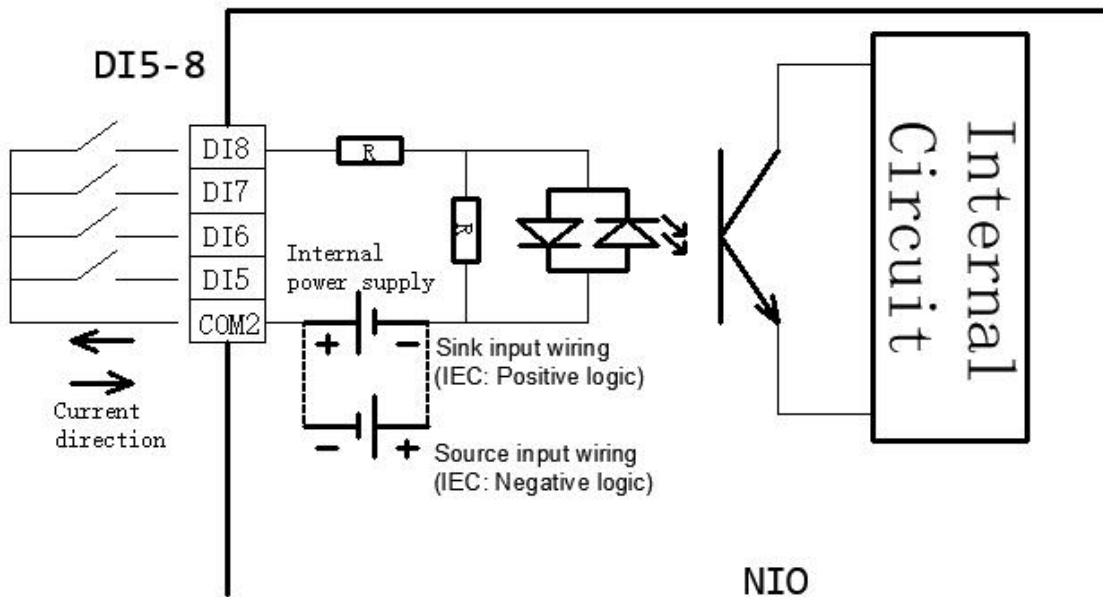

COM2	DI5-8 digital signal input common terminal.
DI5-8	DI5-8 digital signal input.

Note: DI5-8 can be configured with sink or source type, and the default sink type is the factory. The jumper configuration is as follows:

Note: DI1-4 is fixed to sink type. The device already has a built-in power supply for the detection loop.

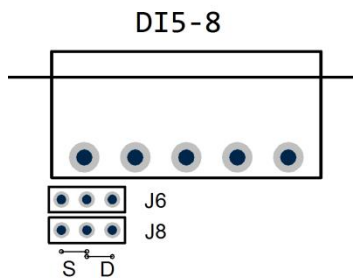

J6 and J8 are jumpered in the D(Drain) direction, they are Sink input(positive logic) types.
 J6 and J8 are jumpered in the S(Source) direction, they are Source input(negative logic) types.

DO1-4: Digital output, Mechanical relay output interface:

DO _n	Mechanical relay output, normally open pin.
RLY _n	Mechanical relay output, normally open pin.

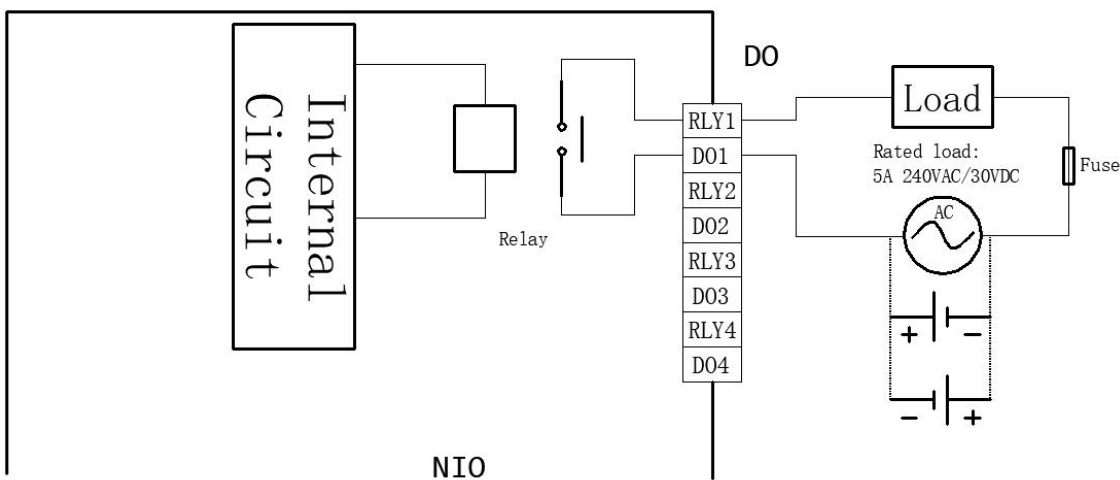

Max switching voltage :277VAC, 30VDC. Maximum switching current: 5A.

Inductive load protection

Inductive load devices such as motors, solenoid coils, and solenoid valves will release the accumulated magnetic energy in the form of back electromotive force at the moment when the power supply is turned off, and then generate high surge voltage, which may cause damage to the equipment or relay output interface. Depending on the type of load circuit, protection circuitry may be required for the relay output. Depending on the type of power supply, you can select a protection circuit from the diagram below.

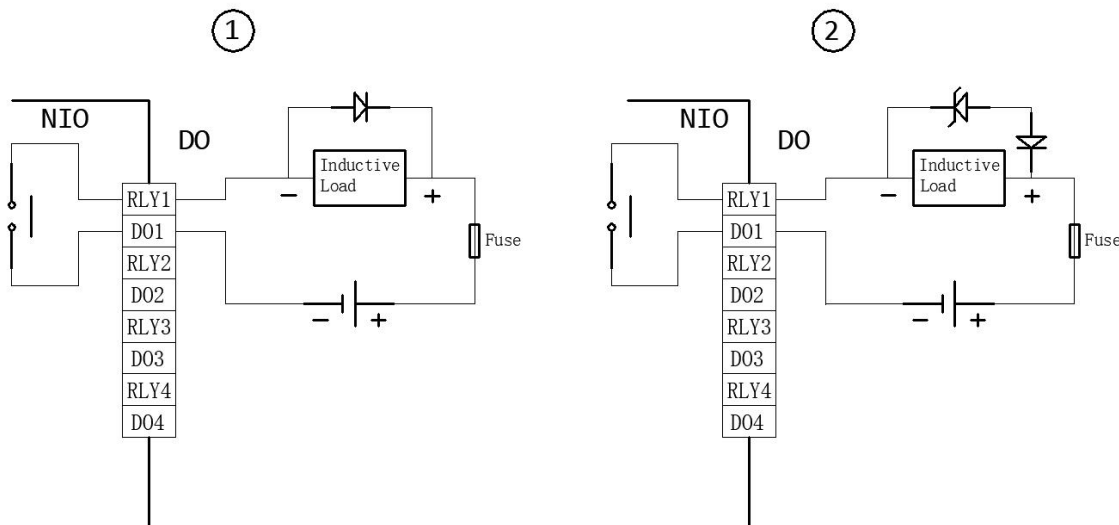

When DC is loaded, you can choose to:

1. With diode protection. Diode parameter selection, reverse withstand voltage value: 10 times the power supply voltage of the load circuit; Forward current value: greater than the load current.
2. With Zener diode protection.

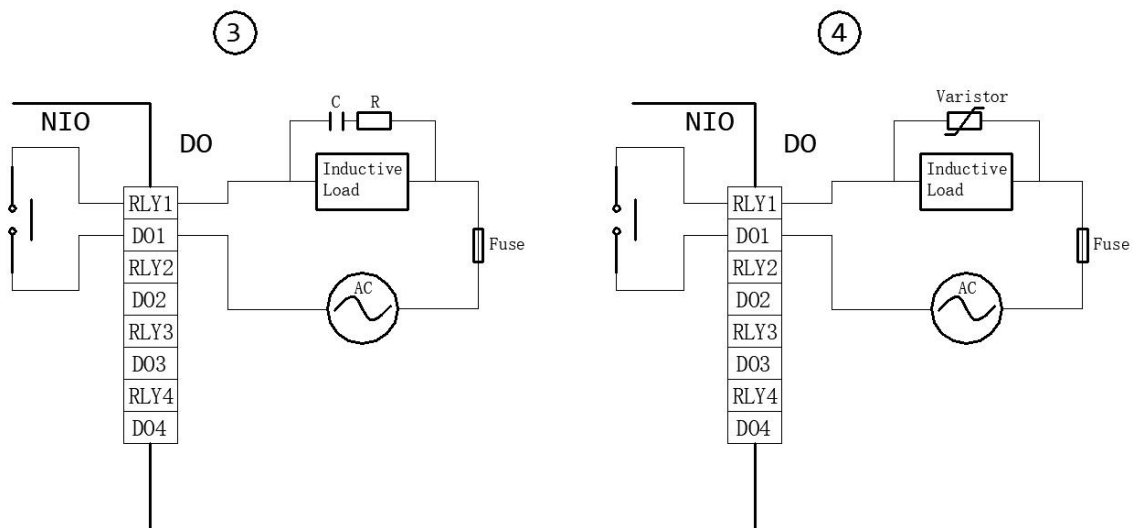

When AC is loaded, you can select:

1. With RC circuit protection. C capacity selection between 0.1uF and 1uF, R resistance value selection about equal load impedance.
2. With Varistor rheostat/varistor protection. The Varistor's continuous energy rating is at least 20% greater than the peak load energy.

Bus : 485 bus interface

+12V	Bus powered output positive pole.
GND	Bus power supply output negative pole.
485A	485 signal positive.
485B	485 signal negative.

Mainly used with Lua scripts

Chapter4 Configure

4.1 General steps

The factory settings are generally not fully suitable for the specific application, and the MN-NIO must be set before use, and the configuration generally follows the following steps:

- (1) Configure local network parameters. Set parameters such as IP address, mask, and gateway. These are assigned by the network administrator.
- (2) Configure the network parameters of the monitoring centre or cloud communication, such as MQTT, SNMP, and ModbusTCP communication parameters.
- (3) Selectively configure the functions of the hardware IO interface according to the needs.
- (4) Configure the reporting interval (optional), which refers to the time interval between the device to report to the monitoring centre or the cloud, in seconds.

4.2 Configuration Method

There are two ways to configure NIO: network connection or serial connection. This section focuses on using a graphical device configuration tool to configure the device over a network connection. The network connection between NIO and the configuration computer can be directly connected through a network cable or through a Layer 2 switch.

The default network configuration of the device is to use the fixed IP address "192.168.0.5" and use the device configuration tool to search for the IP address of the NIO device on the same broadcast domain network. Open the device configuration tool, click "Find" device, you can find the MN device on the current network, select the device to be configured, click "First setup", set the network parameters and load the digital certificate for configuration. If the device is not in the same network segment as the configuration computer, you can click the "Add" button to connect through the specific IP address of the device, please refer to the *Monigear Configtool Userguide.pdf*

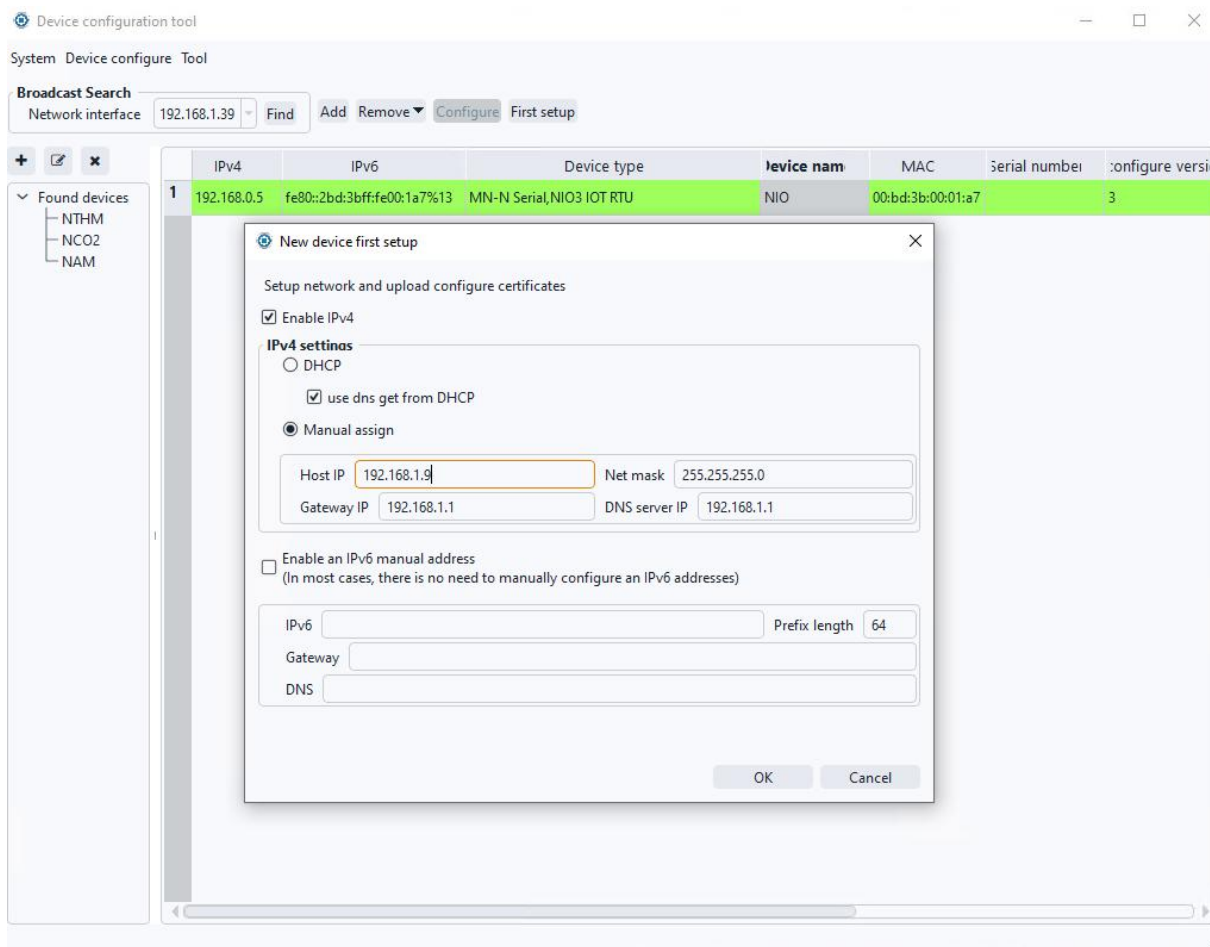

On the device configuration interface, enter the default password *wangkong*, click the connection authentication to pass, and then you can use the tool to configure the device and query the supervisor point data information.

Basic configure: You can set the device host name, IP address, DHCP, NTP, SNMP, Modbus TCP configuration, and IO interface configuration, and so on.

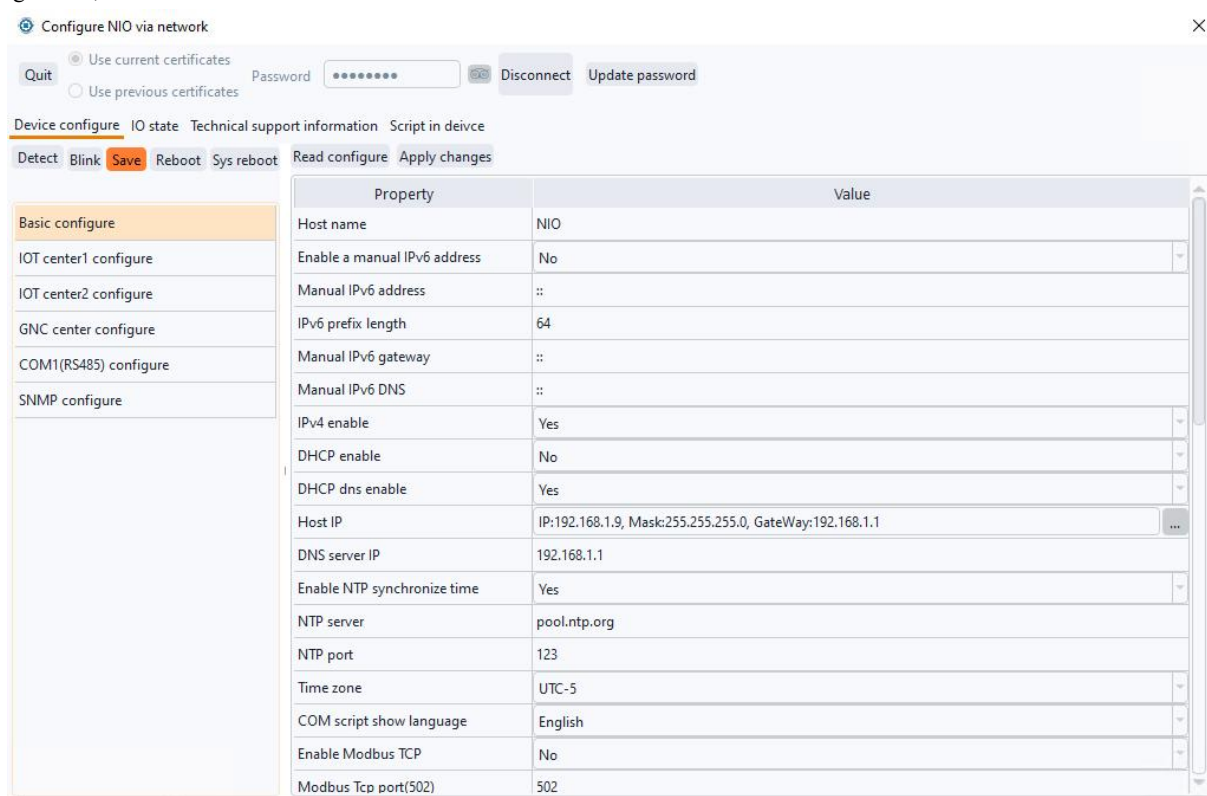

IoT Centre 1/2 settings: You can set MQTT connection options, IoT certificate files, timeout period, center type, and center configuration.

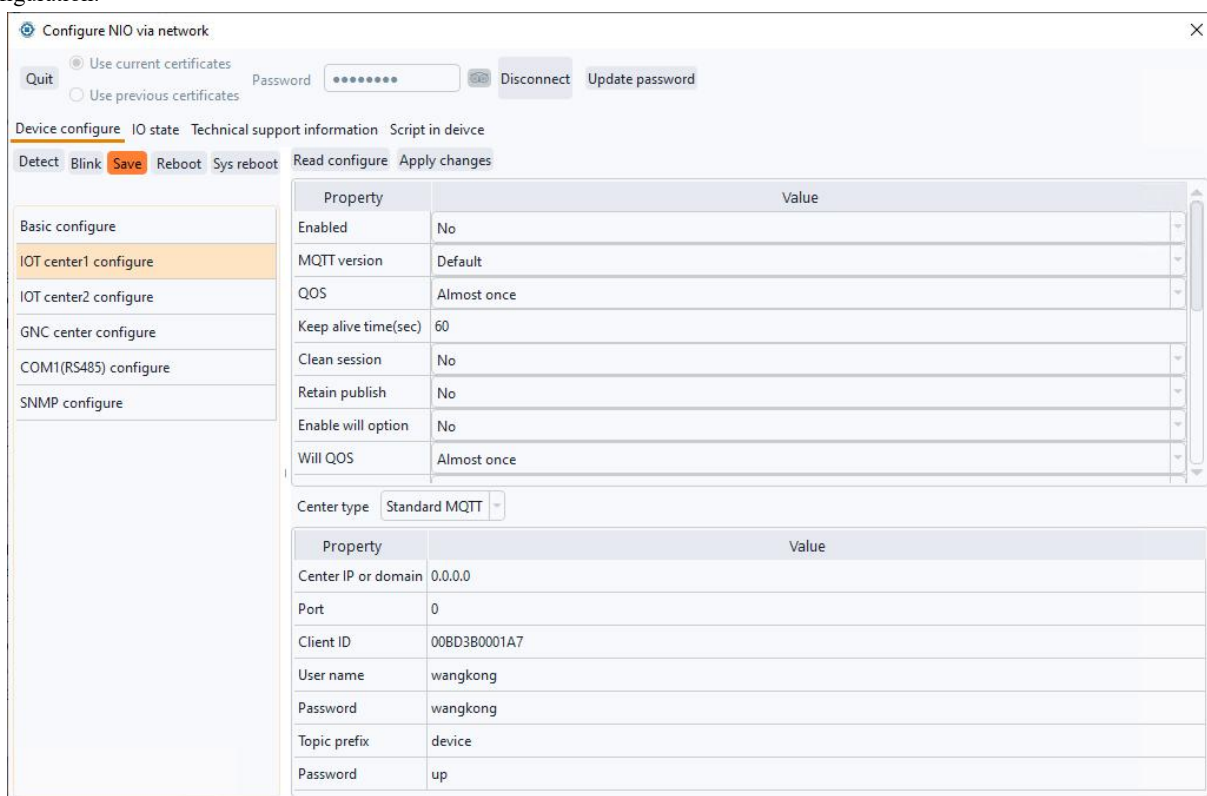

GNC Settings: Set the IP, port, communication key, connection mode, and TLS certificate file of the 1st and 2nd centers.

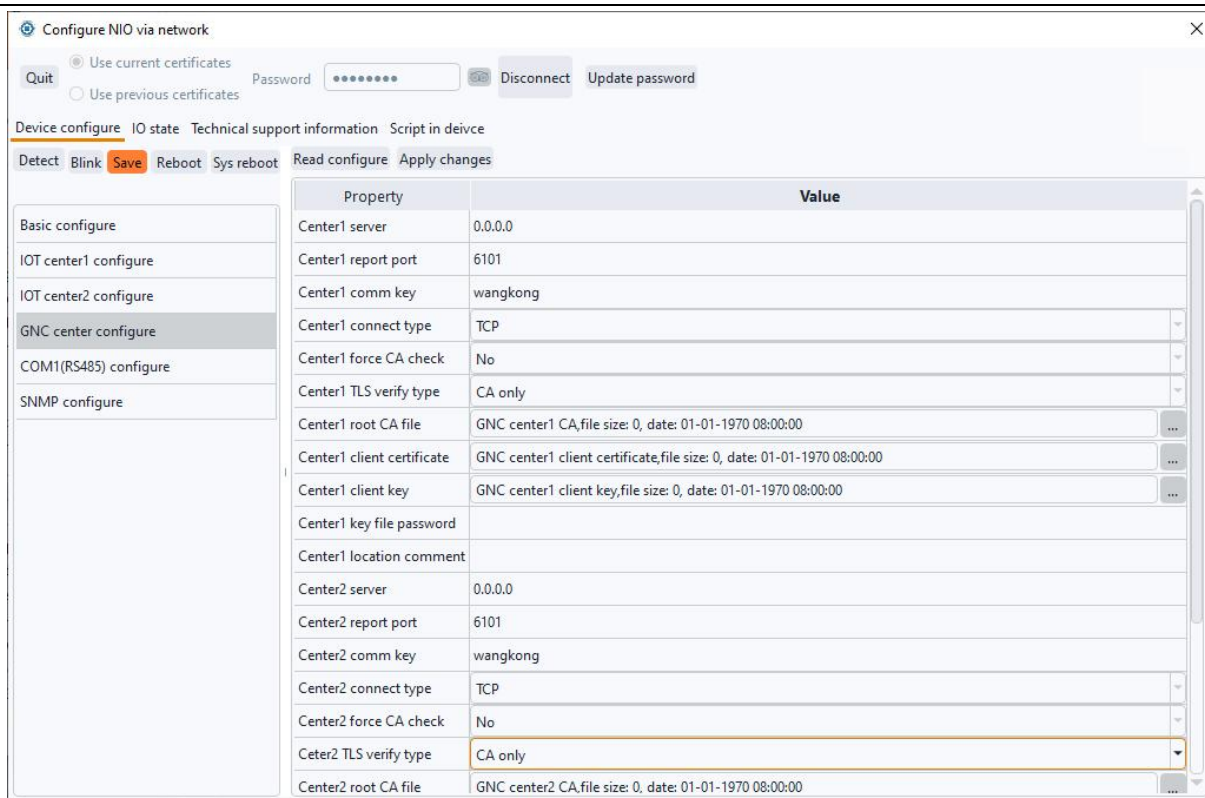

COM1 (RS485) setup: Reserved Bus485 bus interface, supports writing Lua script to collect digital sensor/transmitter data with RS485 interface.

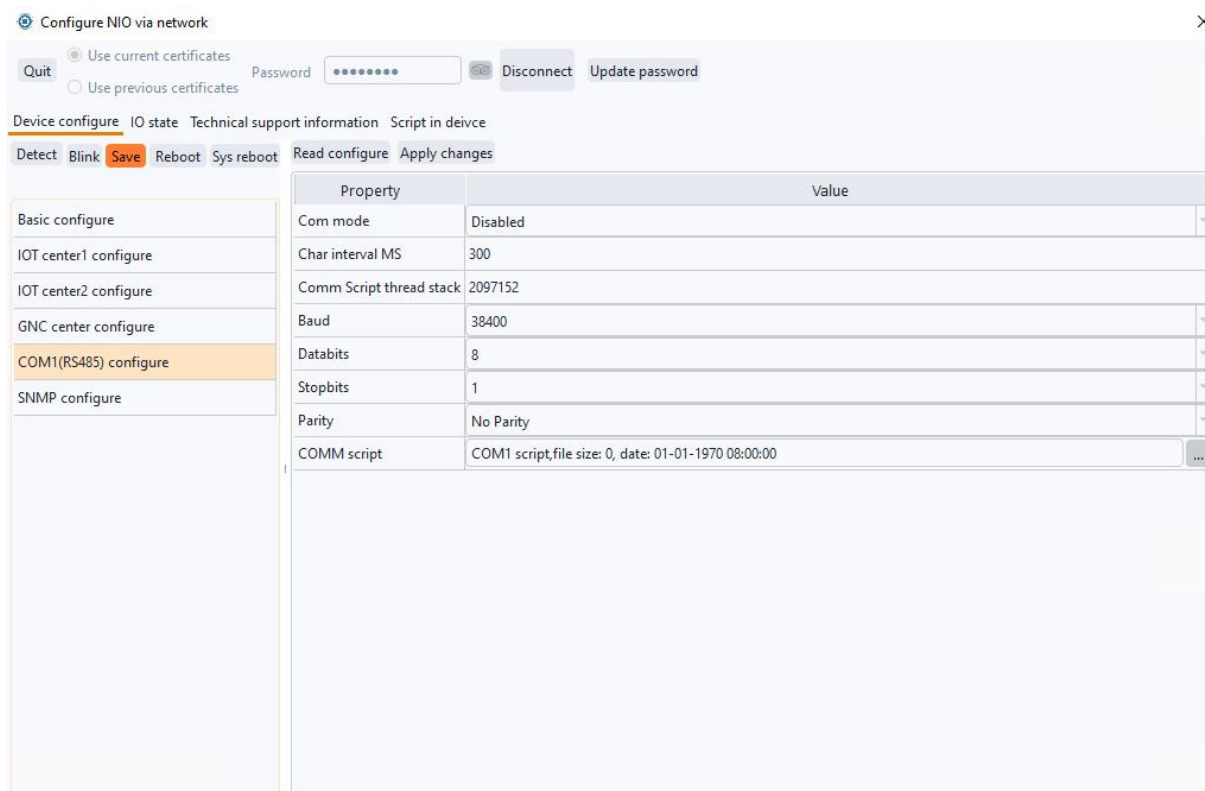

Running Status: The current status of the supervisor point.

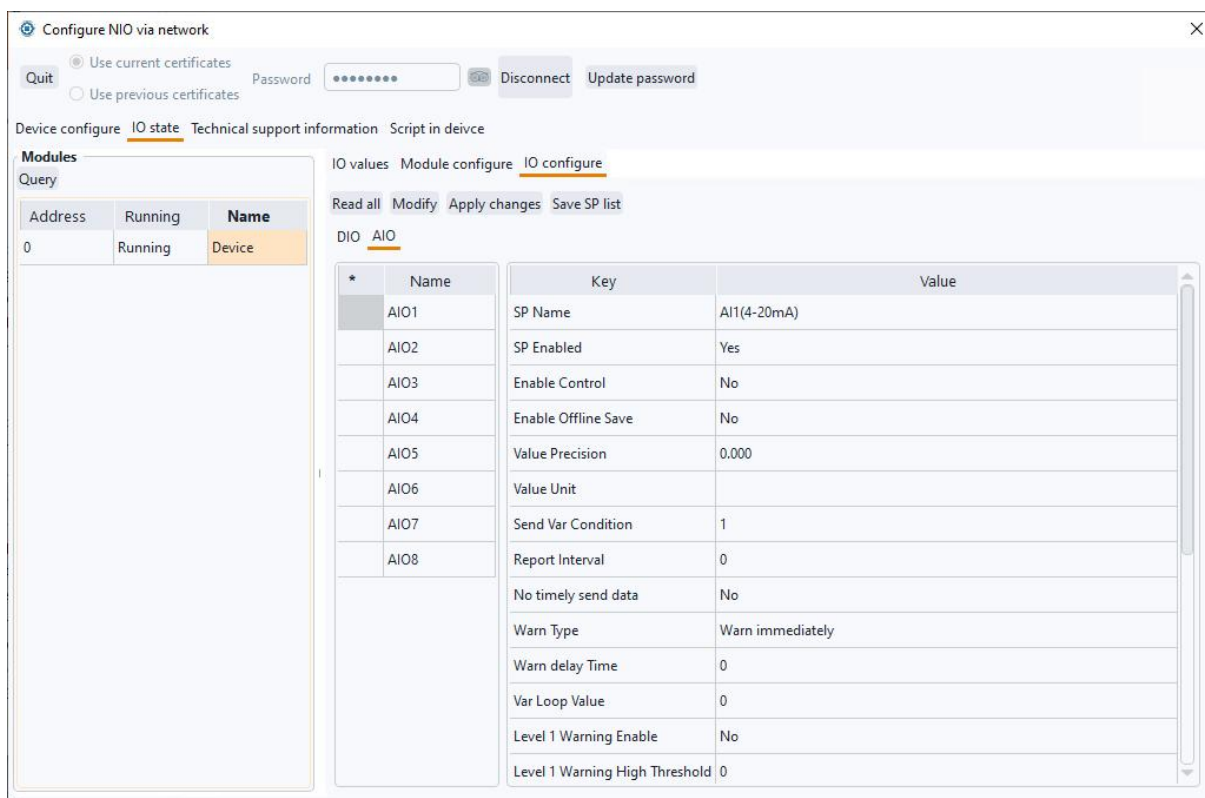

Configure of every AIO/DIO

Technical support information, internal operating status of the equipment and other information. If you encounter any problems and need technical support, you can check the information here and contact our company's technical staff for technical support

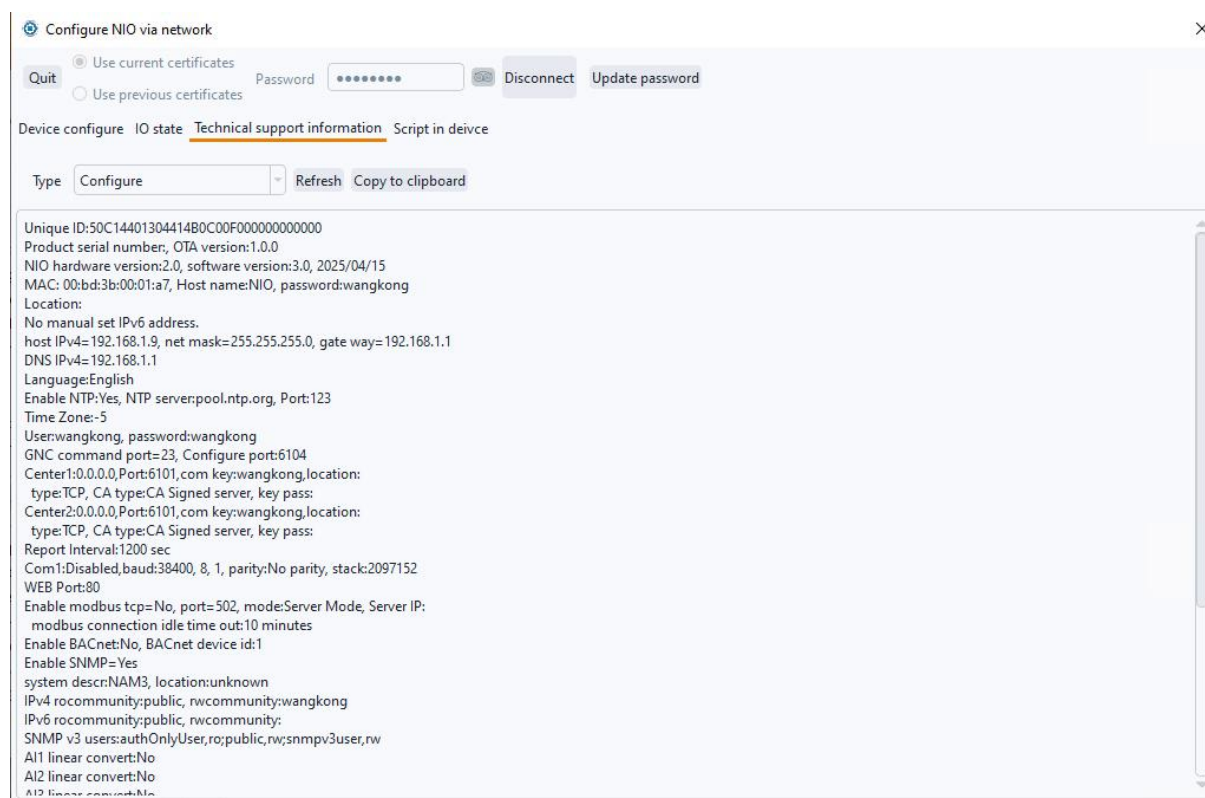

Scripts in device: define device Lua script resources, fixed running script threads, and trigger scripts.

Configure NIO via network
✕

Quit

Use current certificates
 Use previous certificates

Password
Disconnect
Update password

Device configure
IO state
Technical support information
Script in device

Query
Apply to device

Basic configure
Script threads
Triggers

Scripts

+
✎
✕

Index	Stack size
0	1048576

```

--All CO concentration, greater than 30 control DO1 trun on, less than 10 trun off
while(true)
do
  co_val = wk_GetAIOValue(0,1) --Obtain the sensor detection value
  ctrl_val = wk_GetDIOValue(0,9) --In terms of fan status, DO1 ranks 9th in DIO, followed by D11-8
  if (co_val > 30) then
    if ctrl_val == 0 then
      wk_CtrlDO(0,9,1)
    end
  end
  if (co_val < 10) then
    if ctrl_val == 1 then
      wk_CtrlDO(0,9,0)
    end
  end
  wk_Sleep(50); --The thread sleeps for 50ms
end
          
```

Chapter5 Typical Usage

This section uses the analogue input interface (AI), switching input interface (DI), and switching output interface (DO) of NIO as an example to demonstrate how to configure NIO in practical applications. After the device is configured, the NIO acquisition data is obtained through multiple (standard) transmission protocols. In addition, linkage scripts are added to execute custom logic to achieve local automatic control.

5.1 Device configuration

Among them, AI1 is connected to a 4-20mA carbon monoxide transmitter to monitor CO concentration (wiring is for reference only):



DI1 connects to the smoke detector dry contact to monitor the smoke alarm status (wiring is for reference only, the smoke detector also needs to be connected to the power cable):



DO1 is connected to the fan and controls the fan to turn on and off (the wiring is for reference only):

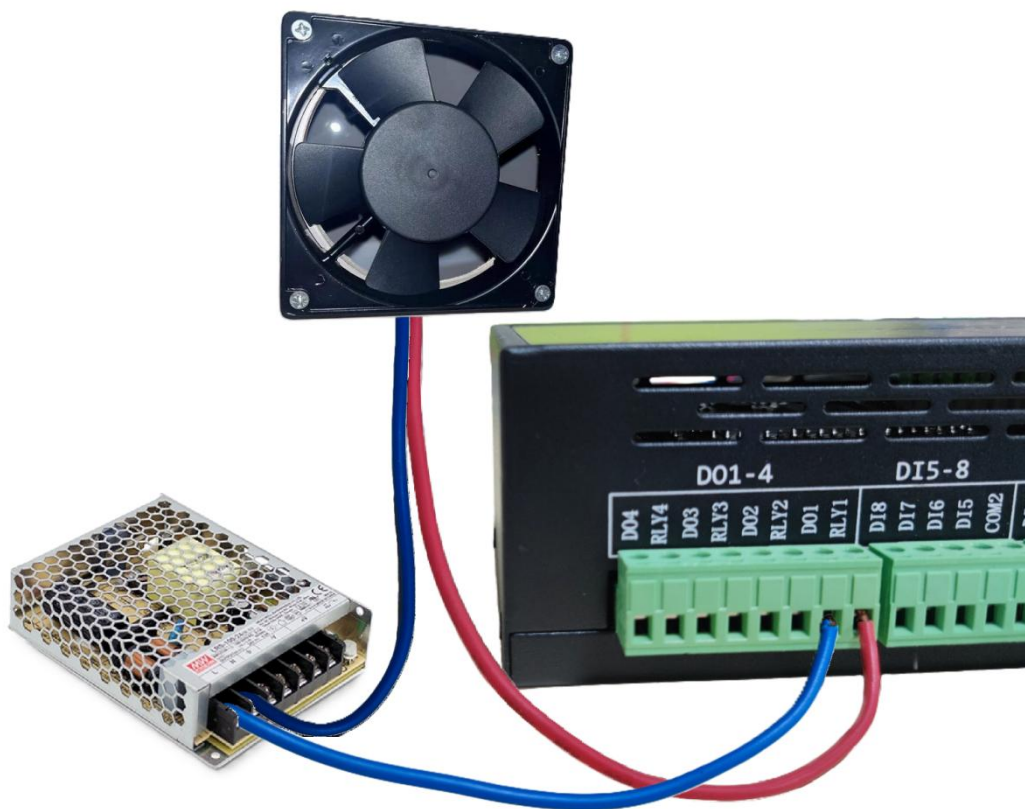

1) Analogue configuration

Go to *Device configure > Basic configure*, enable *A11 linear convert*, and then choose *Apply changes > Save > Reboot*.

Configure NIO via network

Use current certificates Password:

 Use previous certificates

[Device configure](#) [IO state](#) [Technical support information](#) [Script in device](#)

Property	Value
Power on DO state set method	set as default setting
DO1 default value	0
DO2 default value	0
DO3 default value	0
DO4 default value	0
A11 linear convert	Yes
A12 linear convert	No
A13 linear convert	No
A14 linear convert	No
A15 linear convert	No
A16 linear convert	No
A17 linear convert	No
A18 linear convert	No
State led for center type	MQTT IOT
Script license amount	1
Hardware version	2
Hardware sub version	0
Software version	3

Click *IO state > I/O Configure*, select 0 address in the module list, click **Read All** button, select *AIO > AIO1*, and click **Modify** button to modify the supervisor point configuration. For details about the properties of monitoring points, see the [Appendix](#).

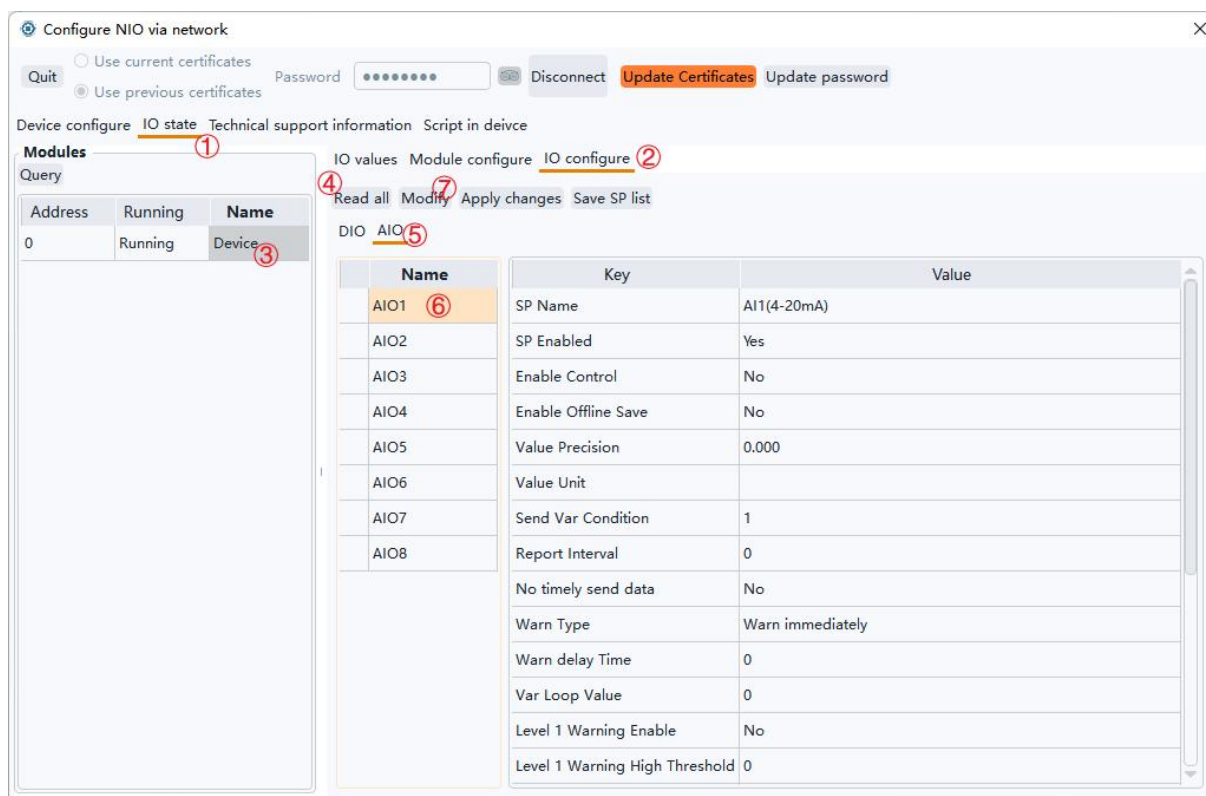

Modify the SP Name, assuming that the range of the carbon monoxide transmitter is 0-500ppm, the resolution is 1ppm, and the modification accuracy is 0, that is, there is no decimal point, the unit ppm, the value changes how much the transmission is set to 1, the Minimum value(lower limit of the effective value) is set to 0, and the Maximum value(upper limit of the effective value) is set to 500, click **OK** to submit the modification.

Property	Value
SP Name	CO concentration
SP Enabled	Yes
Enable Control	No
Enable Offline Save	Yes
Value Precision	0
Value Unit	ppm
Send Var Condition	1
Report Interval	0
No timely send data	No
Warn Type	Warn immediately
Warn delay Time	0
Var Loop Value	0
Level 1 Warning Enable	No
Level 1 Warning High Threshold	0
Level 1 Warning Low Threshold	0
Level 2 Warning Enable	No
Level 2 Warning High Threshold	0
Level 2 Warning Low Threshold	0
Level 3 Warning Enable	No
Level 3 Warning High Threshold	0
Level 3 Warning Low Threshold	0
Minimum value	0
Maximum value	500

2) Digital configuration

For NIO equipment, DIO1-DIO8 corresponds to the digital input interface DI1-DI8; DIO9-DIO12 corresponds to the relay output interface DO1-DO4, and the relay output interface supports remote control to open or close.

Assuming that the smoke detector is normally closed (0-closed, 1-open), refer to the analogue configuration process, modify the configuration attributes, alarm value, alarm level, and 0/1 value description of DI1 (DIO1), as shown in the following figure.

IO values [Module configure](#) [IO configure](#)

[Read all](#) [Modify](#) [Apply changes](#) [Save SP list](#)

[DIO](#) [AIO](#)

Name	Key	Value
* DIO1	SP Name	Smoke detector alarm
DIO2	SP Enabled	Yes
DIO3	Enable Control	No
DIO4	Save data when offline	No
DIO5	Value for warn	1
DIO6	Warn level	2
DIO7	Warn method	Warn immediately
DIO8	Delay warn time(sec)	0
DIO9	Enable lock a short time	No
DIO10	Value for lock	0
DIO11	Lock time(sec)	0
DIO12	D0 describe	Normal
	D1 describe	Alarm

In the same way, modify the configuration attribute (DIO9) of DO1 as shown in the following figure.

IO values [Module configure](#) [IO configure](#)

[Read all](#) [Modify](#) [Apply changes](#) [Save SP list](#)

[DIO](#) [AIO](#)

Name	Key	Value
* DIO1	SP Name	Ventilation fan
DIO2	SP Enabled	Yes
DIO3	Enable Control	Yes
DIO4	Save data when offline	No
DIO5	Value for warn	0
DIO6	Warn level	0
DIO7	Warn method	Warn immediately
DIO8	Delay warn time(sec)	0
* DIO9	Enable lock a short time	No
DIO10	Value for lock	0
DIO11	Lock time(sec)	0
DIO12	D0 describe	Turn off
	D1 describe	Turn on

3) Then click **Apply changes** to complete all the configuration of the supervisor point.

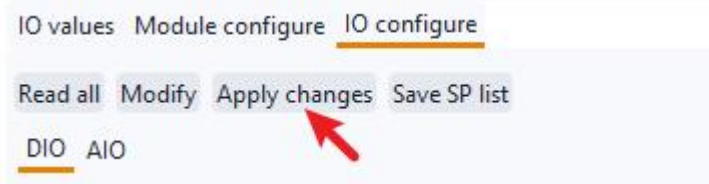

4) View the data of the current supervisor point.

Device configure IO state Technical support information Script in device

Modules

Query

Address	Running	Name
0	Running	Device

IO values Module configure IO configure

Refresh

D11=1,Smoke detector alarm,alarm=2
 D12=1,D12,alarm=0
 D13=1,D13,alarm=0
 D14=1,D14,alarm=0
 D15=1,D15,alarm=0
 D16=1,D16,alarm=0
 D17=1,D17,alarm=0
 D18=1,D18,alarm=0
 DO9=0,Ventilation fan,alarm=0
 DO10=0,DO2,alarm=0
 DO11=0,DO3,alarm=0
 DO12=0,DO4,alarm=0

A11=8.937,CO concentration,alarm=0
 A12=0.000,A12(4-20mA),alarm=0
 A13=0.000,A13(4-20mA),alarm=0
 A14=0.000,A14(4-20mA),alarm=0
 A15=0.000,A15(4-20mA),alarm=0
 A16=0.000,A16(4-20mA),alarm=0
 A17=0.000,A17(4-20mA),alarm=0
 A18=0.000,A18(4-20mA),alarm=0

Simulate the alarm state and turn on the fan:

Device configure IO state Technical support information Script in device

Modules

Query

Address	Running	Name
0	Running	Device

IO values Module configure IO configure

Refresh

D11=1,Smoke detector alarm,alarm=2
 D12=1,D12,alarm=0
 D13=1,D13,alarm=0
 D14=1,D14,alarm=0
 D15=1,D15,alarm=0
 D16=1,D16,alarm=0
 D17=1,D17,alarm=0
 D18=1,D18,alarm=0
 DO9=1,Ventilation fan,alarm=0
 DO10=0,DO2,alarm=0
 DO11=0,DO3,alarm=0
 DO12=0,DO4,alarm=0

A11=118.250,CO concentration,alarm=0
 A12=0.000,A12(4-20mA),alarm=0
 A13=0.000,A13(4-20mA),alarm=0
 A14=0.000,A14(4-20mA),alarm=0
 A15=0.000,A15(4-20mA),alarm=0
 A16=0.000,A16(4-20mA),alarm=0
 A17=0.000,A17(4-20mA),alarm=0
 A18=0.000,A18(4-20mA),alarm=0

5.2 Acquire hardware acquisition data

MN devices provide a variety of ways to acquire hardware acquisition data (only the results of different methods are demonstrated here, please refer to the relevant documentation for the configuration of each protocol).

1. GNC protocol(GNC-SCADA data acquisition management system)

Using the GNC-specific protocol, the device can be configured remotely; it can obtain all the attribute configurations of the supervisor point and support remote modification of the attributes of the supervisor point; support remote control of supervisor point range. In addition, GNC-SCADA can process and record the data collected by the device and send SMS, email, and phone calls to notify users when an alarm is generated at the supervisor point.

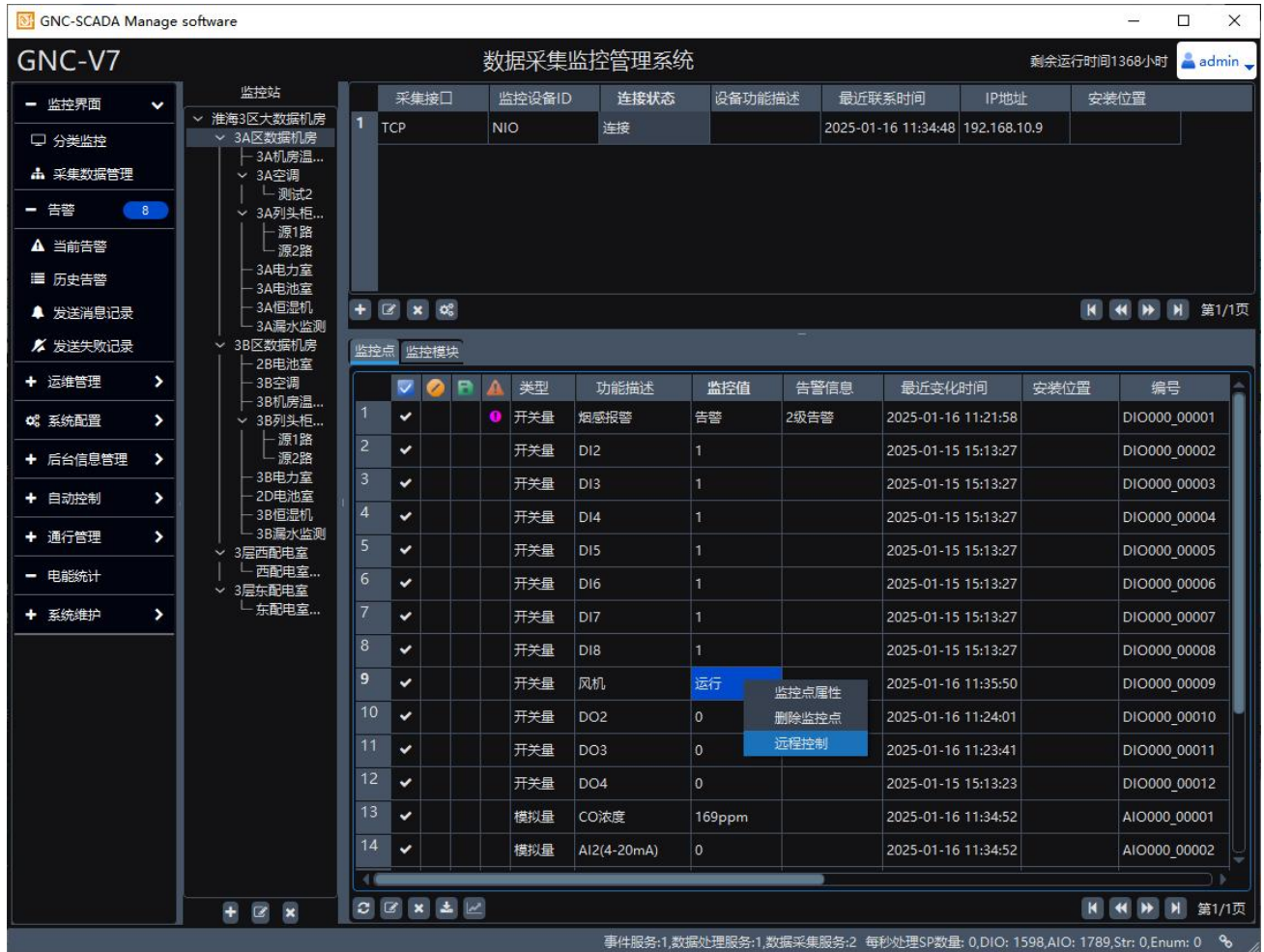

Data Logging & Curves:

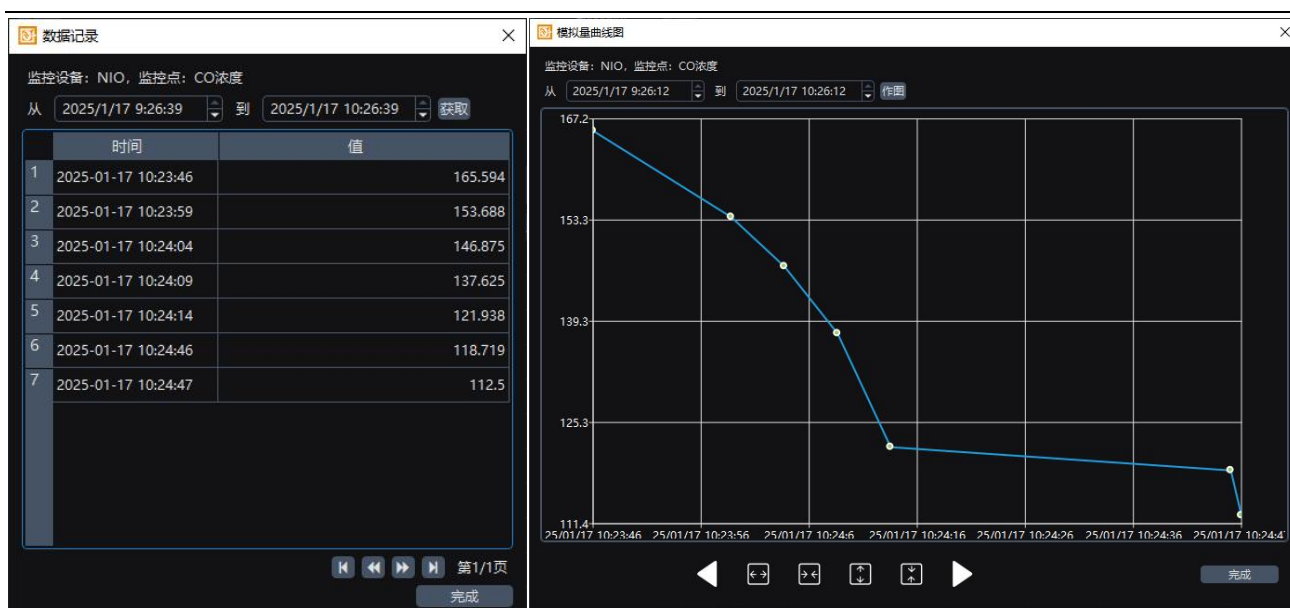

2. MQTT protocol, such as AWS IoT.

AIO data published by the device:

The screenshot shows the Amazon IoT console interface. A message is displayed for the device 'device/gnc-nio/up' published on January 16, 2025, at 17:47:32 (UTC+0800). The message content is a JSON object with the following structure:

```

{
  "type": "up",
  "time": "20250116044731",
  "dev": "NIO",
  "aiolist": [
    "1 0 168.625000 0",
    "2 0 0.000000 0",
    "3 0 0.000000 0",
    "4 0 0.000000 0",
    "5 0 0.006000 0",
    "6 0 0.000000 0",
    "7 0 0.006000 0",
    "8 0 0.006000 0"
  ]
}
    
```

DIO data published by the device:

▼ device/gnc-nio/up
January 16, 2025, 17:47:31 (UTC+0800)

```

{
  "type": "up",
  "time": "20250116044731",
  "dev": "NIO",
  "diolist": [
    "1 0 1 2",
    "2 0 1 0",
    "3 0 1 0",
    "4 0 1 0",
    "5 0 1 0",
    "6 0 1 0",
    "7 0 1 0",
    "8 0 1 0",
    "9 0 0 0",
    "10 0 0 0",
    "11 0 0 0",
    "12 0 0 0"
  ]
}
            
```

▶ Properties

The application publishes control topic data and controls DO1 to be turned on/off.

Subscribe to a topic
Publish to a topic

Topic name
The topic name identifies the message. The message payload will be published to this topic with a Quality of Service (QoS) of 0.

Message payload

▶ Additional configuration

3. Modbus TCP protocol

Reading the data acquired by the device via Modbus TCP:

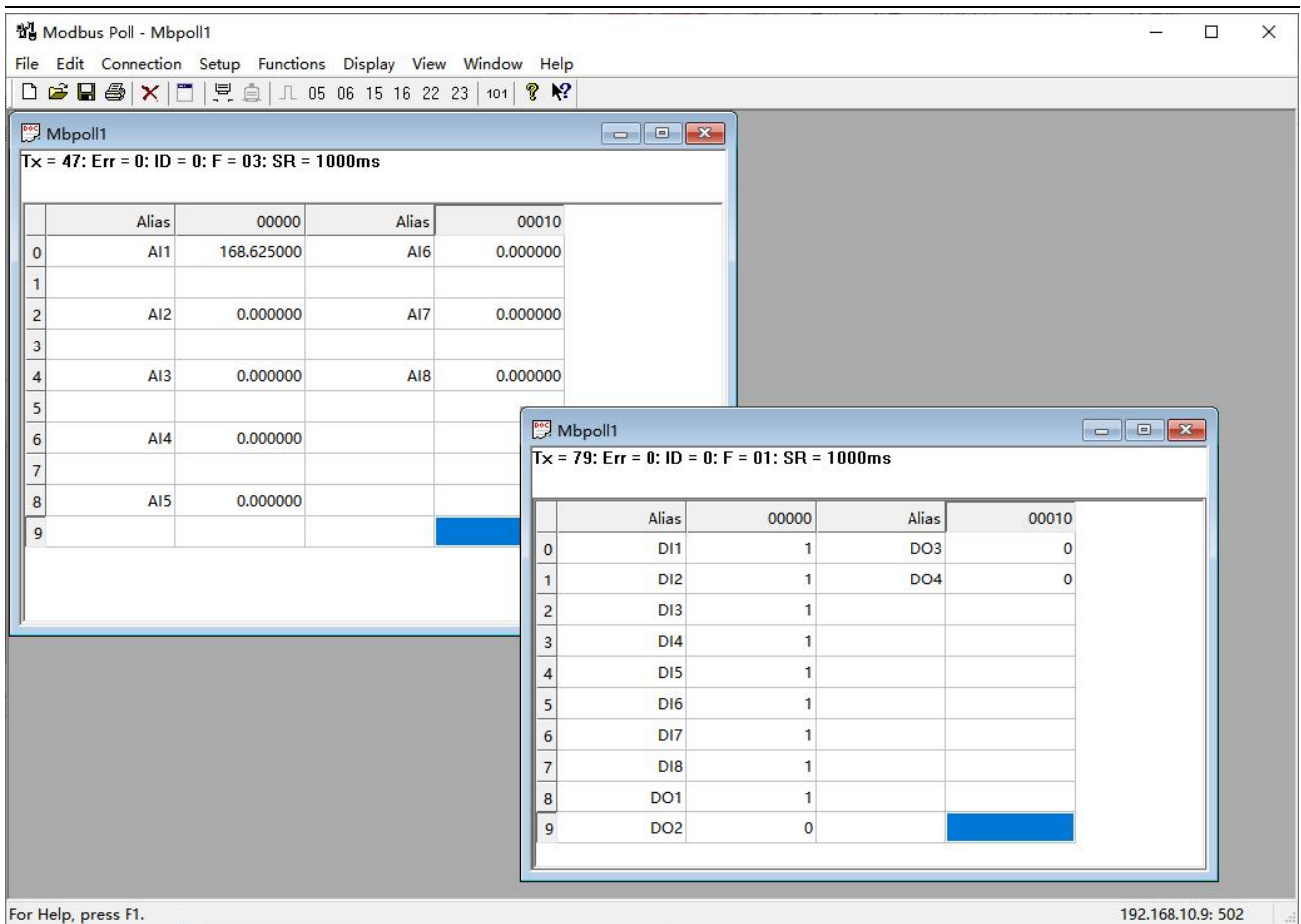

Use Modbus TCP command control to turn on/off the fan:

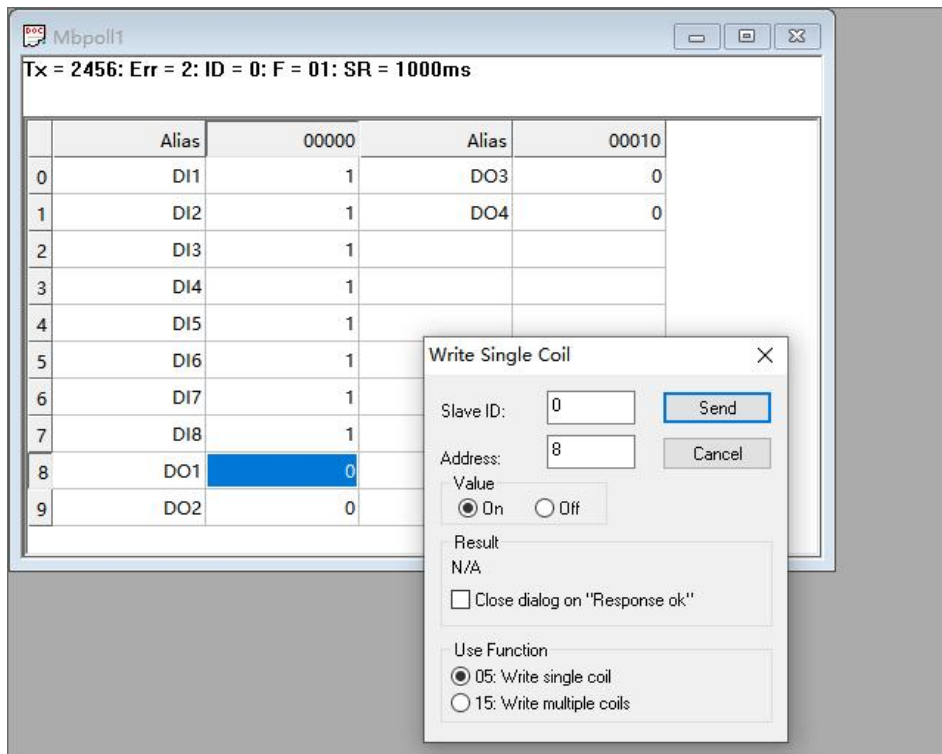

4. SNMP protocol

Acquired AIO data by SNMP:

Use SNMP SET control to turn on/off the fan:

The screenshot shows the iReasoning MIB Browser interface. On the left, a tree view displays the MIB structure: iso.org.dod.internet.private.enterprises.wangkong.wangkongRTU.productInfo.dioTable.dioEntry.dioValue. The main window displays a table of values for dioValue entries (dioValue.1 to dioValue.12) with columns for Name/OID, Value, Type, and IP:Port. An 'SNMP SET' dialog box is open, showing the selected OID (.1.3.6.1.4.1.22853.1.2.1.2.9), Data Type (Integer), and Value (1). The dialog box has 'Ok' and 'Cancel' buttons.

Name/OID	Value	Type	IP:Port
sioValue.1	168.625000	OctetSt...	192.168.1...
sioValue.2	0.000000	OctetSt...	192.168.1...
sioValue.3	0.000000	OctetSt...	192.168.1...
sioValue.4	0.000000	OctetSt...	192.168.1...
sioValue.5	0.000000	OctetSt...	192.168.1...
sioValue.6	0.000000	OctetSt...	192.168.1...
sioValue.7	0.000000	OctetSt...	192.168.1...
sioValue.8	0.000000	OctetSt...	192.168.1...
dioValue.1	1	Integer	192.168.1...
dioValue.2	1	Integer	192.168.1...
dioValue.3	1	Integer	192.168.1...
dioValue.4	1	Integer	192.168.1...
dioValue.5	1	Integer	192.168.1...
dioValue.6	1	Integer	192.168.1...
dioValue.7	1	Integer	192.168.1...
dioValue.8	1	Integer	192.168.1...
dioValue.9	0	Integer	192.168.1...
dioValue.10	0	Integer	192.168.1...
dioValue.11	0	Integer	192.168.1...
dioValue.12	0	Integer	192.168.1...

5. BACNet

Use Yabe view data.

The screenshot shows the Yet Another Bacnet Explorer (Yabe) interface. The 'Devices' pane on the left shows a tree view of devices, including 'GNC-NIO NIO (G)'. The 'Address Space' pane shows a list of objects, including 'ANALOG INPUT 1 (AI:0)'. The 'Properties' pane on the right shows details for the selected object, including Object Identifier, Object Name, Object Type, Present Value, Status Flags, Event State, Out Of Service, Units, Description, Reliability, Cov Increment, and Proprietary values. The 'Log' pane at the bottom shows network activity.

Object Identifier	Value
OBJECT_ANALOG_INPUT:0	
ANALOG INPUT 1	
Object Type	0 : Object Analog Input
Present Value	0
Status Flags	0000
Event State	0 : Normal
Out Of Service	False
Units	95 : No Units
Description	ANALOG INPUT 1
Reliability	0 : No Fault Detected
Cov Increment	1
Proprietary - 9997	90.51
Proprietary - 9998	90
Proprietary - 9999	-200

Explain

When you use GNC and MQTT to acquire data collected by a device, the device is triggered by a scheduled or conditional request to report the data.

① The device will report all supervisor data on a regular basis, and the default interval is 1200 seconds, that is, 20 minutes, and it will be modified in the basic settings (to be updated)

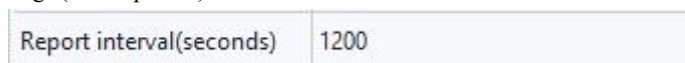

② Each AIO can be sent at a different interval by setting the **Report Interval**, and you can also set **No timely send data** to whether to report the monitoring values at the same time as the device regularly reports the data of all monitoring points, refer to the [Appendix](#).

③ Conditionally triggered report

For DIO, whenever there is a change in value, it is reported.

For AIO, when the **Send Var Condition** is set to non-0, refer to the [Appendix](#).

④ Alarm level change, For example, the AIO changes from Level 1 alarms to Level 2 alarms.

When you use Modbus TCP, SNMP, or BACNet protocols to acquire device data, the monitoring centre or host computer needs to continuously scan or poll the device data.

5.3 Lua scripts

Write a Lua linkage script to achieve local automatic control; when the CO concentration is too high, automatically turn on the fan, and when the CO concentration drops, automatically turn off the fan. Local linkage scripts can be run off-network.

Select **Script in device**, click **Query** button, select the **Script threads** that runs fixedly, click “+” button, enter the script text, and then click **Apply to the device**. Finally, return to the basic configuration page and reboot the device to take effect.

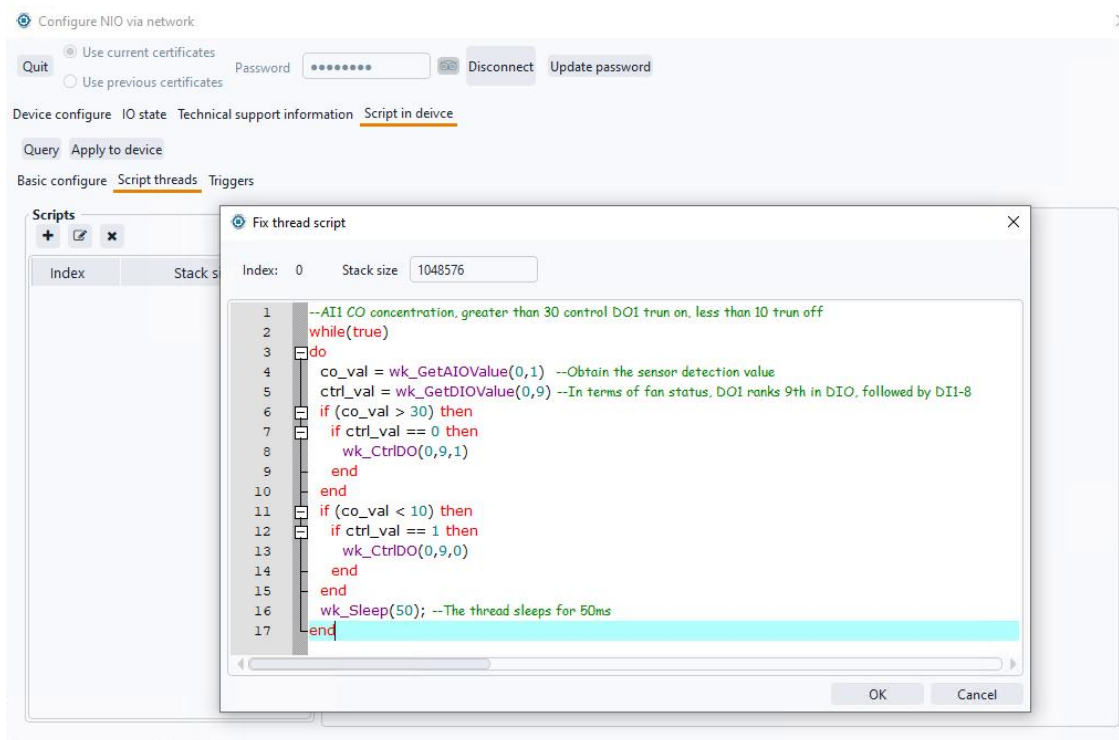

Sample script content:

```
--AI1 CO concentration, greater than 30 control D01 trun on, less than 10 trun off
while(true)
do
  co_val = wk_GetAIOValue(0,1) --Obtain the sensor detection value
  ctrl_val = wk_GetDIOValue(0,9) --In terms of fan status, D01 ranks 9th in DIO, followed by DI1-8
  if (co_val > 30) then
```

```
if ctrl_val == 0 then
  wk_CtrlDO(0,9,1)
end
end
if (co_val < 10) then
  if ctrl_val == 1 then
    wk_CtrlDO(0,9,0)
  end
end
end

wk_Sleep(50); --The thread sleeps for 50ms
end
```

Appendix

- ◆ DIO(Digital Input Output) configuration: including whether the channel is enabled, the value of the alarm, the level of the alarm, whether it is a security supervisor point, and the delay alarm time.

DIO configuration attribute	optional	explanation
SP Name		Functional description of analogue supervisor point.
SP Enabled	Yes	This supervisor point is enabled and will report to the data center when it meets the conditions.
	No	This supervisor point is not enabled and will not report to the data center.
Enable Control	Yes	The relay output DO or remotely adjustable digital output is Yes.
	No	The digital input is No.
Save data when offline	Yes	Need save historical data.
	No	No need to save historical data.
Value for warn	0	Generate an alarm when the value of the switch is 0.
	1	Generate an alarm when the value of the switch is 1.
Warn level		This option can only be 0, 1, 2, 3 (0 means no alarm enabled).
Warn method	Warn immediately	When the switch value is the same as the value at the time of the alarm, an alarm is immediately generated.
	Warn after delay a period	The switch value is the same as the value at the time of the alarm and is maintained for a period of time before the alarm is generated.
Delay warn time(sec)		Used in conjunction with the previous item.
Enable lock a short time		For frequently changing switch signals, frequent alarms will occur. Enabling it can solve the problem of frequent alarms.
Value for lock		When a certain state lock is enabled for a period of time, if the switch value changes to the locked value, the monitoring value remains in the locked state during the locked time, regardless of whether the value of the monitoring point changes during this period.
Lock time(sec)		The time during which the monitoring value remains unchanged when the locking function is enabled.
D0 describe		Functional description when the digital supervisor point value is 0.
D1 describe		Functional description when the digital supervisor point value is 1.

- ◆ AIO(Analogue Input Output) configuration: including whether the channel is enabled, the accuracy unit, the upper and lower limits of the effective value, the level of the alarm, the delay alarm time, etc.

AIO configuration attribute	optional	explanation
SP Name		Functional description of digital supervisor point.
SP Enabled	Yes	This supervisor point is enabled and will report to the data center when it meets

		the conditions.
	No	This supervisor point is not enabled and will not report to the data center.
Enable Control	Yes	The analogue output or remotely adjustable analogue is Yes.
	No	The analogue input is NO.
Enable Offline Save	Yes	Need save historical data.
	No	No need to save historical data.
Value Precision	The display accuracy of supervisor values, e.g.set to 0.0, i.e. one decimal place is retained.	
Value Unit	The unit of monitoring value, such as meters, °C, etc.	
Send Var Condition	If the deviation between the current monitoring value and the last reported value is greater than this value, the monitoring data will be reported to the center software..	
Report Interval	The frequency of reporting this supervisor point value to the centers, 1200 seconds by default.	
No timely send data	Yes	When the device regularly reports all the monitoring data, the value of the supervisor point is not reported.
	No	When the device regularly reports all the monitoring data, the value of the supervisor point is reported.
Warn Type	Warn immediately	Immediately change alarm value when the monitoring value exceeds or falls below the alarm upper limit or lower limit. When alarm level changed report immediately.
	Warn after delay a period	The monitoring value is higher than the alarm upper limit or lower than the alarm lower limit and only generates an alarm after maintaining it for a period of time.
Warn delay Time	Used in conjunction with the previous item.	
Var Loop Value	The difference between the current monitoring value and the alarm threshold needs to be greater than the loop back protection threshold to meet the alarm cancellation condition, which can avoid frequent triggering of alarms near the critical point.	
Level 1/2/3 Warning Enable	When the monitoring value meets the conditions, a corresponding level of alarm will be generated.	
Level 1/2/3 Warning High Threshold	When the monitoring value exceeds the upper limit of the alarm, a corresponding level of alarm will be generated.	
Level 1/2/3 Warning High Threshold	When the monitoring value is below the lower limit of the alarm, a corresponding level of alarm will be generated.	
Minimum value	The corresponding value of the lower limit of the range of the external transmitter.	
Maximum value	The corresponding value of the upper limit of the range of the external transmitter.	